



Montanari Group

GEARLESS&GEARBOX
TRACTION MACHINES



**INSTALLATION, USE AND MAINTENANCE
GEARBOXES FOR ESCALATORS
AND MOVING WALKWAYS**

M93ES

Thank you for choosing a Montanari gearbox.

For over 45 years, Montanari Group has been focused on providing its customers with the best traction machines and components for lifts and escalators.

We are proud to have you as a customer and user of the Montanari traction machines, and we are confident that we can work together for a long time.

Thanks again for your choice.

Massimo Montanari
CEO of Montanari Group



CONTENTS

1. GENERAL INFORMATION.....	7
1.1 Introduction.....	7
1.2 Copyright.....	7
1.3 Symbols used.....	8
2. SAFETY	9
2.1 Intended use.....	9
2.2 User's obligations.....	9
2.3 Environmental protection.....	10
2.4 Specific hazards	10
3. IDENTIFICATION AND DATA.....	11
3.1 Identification plate.....	11
3.2 Technical data	12
3.3 Other data	12
3.4 Dimensions	13
3.5 Oil quantity.....	14
4. TRANSPORT AND STORAGE.....	15
4.1 Handling	15
4.2 Storage.....	16
4.3 Standard corrosion protection.....	16
5. DESCRIPTION	18
5.1 General description	18
5.2 Main components.....	18
5.3 Oil plugs and indicators.....	19
6. INSTALLATION.....	20
6.1 General installation information	20
6.2 Installation surface.....	20
6.3 Installation procedure	20
7. OPERATION.....	22
7.1 Preliminary operations	22
7.2 Connections.....	22
7.3 Additional components.....	22
7.4 General operation information	23



8. TROUBLESHOOTING	24
8.1 General information.....	24
8.2 Problems, causes and solutions.....	24
9. MAINTENANCE AND REPAIR	25
9.1 General information.....	25
9.2 Maintenance table	25
9.3 Description of maintenance activities.....	26
9.4 Lubricants	27
10. SPARE PARTS.....	29
10.1 General information.....	29
10.2 How to order spare parts.....	29
10.3 How to identify spare parts	29
10.4 Table 1 - Motor.....	30
10.5 Table 2 - Brake.....	31
10.6 Table 3 - Magnet.....	32
10.7 Table 4 - Slow Shaft.....	33
10.8 Table 5 - Worm Shaft.....	34
11. DECLARATION OF INCORPORATION	36

1. GENERAL INFORMATION

1.1 Introduction

These operating instructions are an integral part of the supplied gearbox and must always be kept within easy reach for consultation.

All persons involved in the installation, operation, maintenance and repair of the unit must have read and understood the instructions.

No liability is accepted for damage, breakage or accident caused by failure to follow the instructions provided in this manual.

The Montanari M93ES gearbox described herein has been designed and manufactured in accordance with the recognized safety standards and the state of the art technical development applied at the time of printing these instructions.

To make technical improvements, Montanari reserves the right, if deemed necessary, to modify the units and accessories, preserving their essential characteristics and improving efficiency and safety.

1.2 Copyright

All rights to these operating instructions belong to Montanari Giulio & C. S.r.l.

The information in this manual may not be reproduced or used in an unauthorized manner or made available to third parties without prior permission.

If you have any questions, please contact:

 MONTANARI GROUP
HEADQUARTERS - MONTANARI GIULIO & C. S.r.l.
Via Bulgaria, 39 - 41122 - Modena - Italy
Phone: +39 059 453611 - Fax: +39 059 315890
www.montanarigiulio.com
info@montanarigiulio.com



1.3 Symbols used

Warning symbols used in this manual:



This symbol indicates that safety measures must be taken to prevent personal injury.



This symbol indicates that safety measures must be taken to prevent damage to components.



This symbol indicates useful information before and during the installation step.

2. SAFETY

2.1 Intended use

The Montanari M93ES gearbox has been manufactured in accordance with the state of the art technology and is supplied ready for safe and reliable use. Any modification by the user that may affect safety or reliability is prohibited; it is also prohibited to tamper with devices or functions designed to prevent accidental contact.

The Montanari M93ES gearbox must be used and operated in strict compliance with the conditions set out in the supply contract.



It is forbidden to use the Montanari M93ES gearbox for activities other than the one for which it was produced.

2.2 User's obligations

The operator must ensure that all persons involved in installation, operation, maintenance and repair have read and understood the supplied operating instructions and have adapted to them in order to:

- Avoiding damage to property or persons
- Ensure safe and reliable operation of the unit
- Avoid breakage and environmental damage due to misuse.

In particular:

- During transport, assembly, installation, operation, maintenance and dismantling of the unit, the relevant environmental and safety standards must always be complied with.
- The unit must only be used, maintained and repaired by authorized, properly trained and qualified personnel.
- The gearbox must not be cleaned using high-pressure cleaning equipment.
- All work must be carried out with care and with due attention to safety.
- Any work on the unit should only be carried out when it is not in operation.
- The unit must be protected against accidental starting (e.g. by locking the key switch or removing fuses from the power supply). A warning must be placed on the starting switch to clearly indicate that work is in progress on the unit.
- No welding work must be carried out on the unit.
- The unit must not be used as a grounding point for welding operations. Toothed gears and bearings can be irreparably damaged by welding.



- If any changes are detected (e.g. overheating or unusual noise) during operation, the unit must be switched off immediately.
- Rotating components such as pinions and handwheels must be equipped with appropriate guards to prevent contact.
- If the unit is intended for installation in plant or machinery, the manufacturer of such plant or machinery must ensure that the standards, indications and descriptions contained in these operating instructions are incorporated into its own instructions.
- The information on the warning or identification plates must be complied with. These plates must be kept clean and legible at all times. Missing plates must be replaced.

All spare parts can be obtained from Montanari Group.

2.3 Environmental protection

- When replacing the oil, the used oil must be collected in suitable containers.
- Any oil leaks must be removed immediately.
- Used oil, protective agents, binders and oil-soaked cloths must be disposed of in accordance with environmental legislation.

2.4 Specific hazards

Depending on the conditions of use, the surface of the unit can become very hot.



Danger of burning! When changing oil, take care to avoid burning with boiling oil.

3. IDENTIFICATION AND DATA

3.1 Identification plate

The following plate is affixed to the unit.

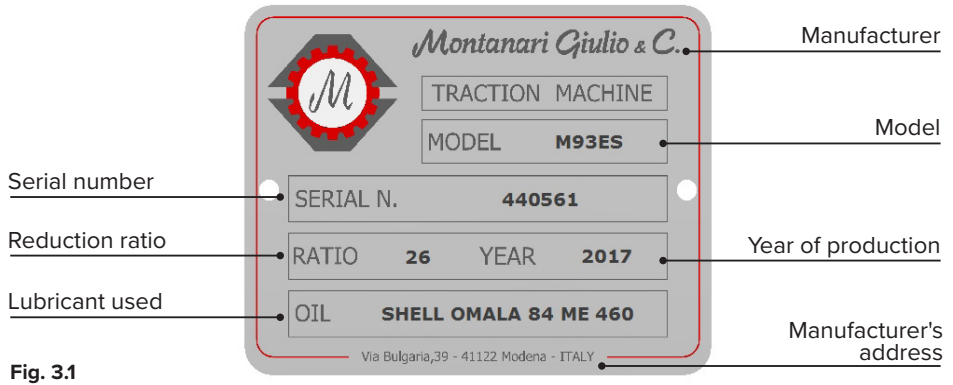

Fig. 3.1

The data on the plate are:

- Manufacturer's data and logo
- Year and place of production
- Serial number
- Model
- Reduction ratio
- Type of lubricant used



3.2 Technical data

The following table shows the main technical data of the unit, depending on the version.

Versione <i>Version</i>	Rapporto <i>Ratio</i>	Vel. uscita <i>Output speed</i>	Momento torc. max. <i>Max torque</i>	Potenza <i>Power</i>	Rendimento ⁽¹⁾ <i>Efficiency</i>	Peso <i>Weight</i>
		RPM	Nm	kW	Full load	kg
M93ES-7.5-6P	24.5	39.18	1499	7.5	0.85	355
M93ES-11-6P	24.5	39.18	2198	11	0.85	390
M93ES-15-6P	24.5	39.18	2998	15	0.85	410

⁽¹⁾ Solo argano / Gearbox only

3.3 Other data

Below is a table with other data.

Notes	
Protection	IP55
Operating temperature	max. 40°C
Synthetic oil	ISO VG460
Brake	220 V AC + Booster; 2x140 Nm

3.4 Dimensions

The following drawing shows the overall dimensions.

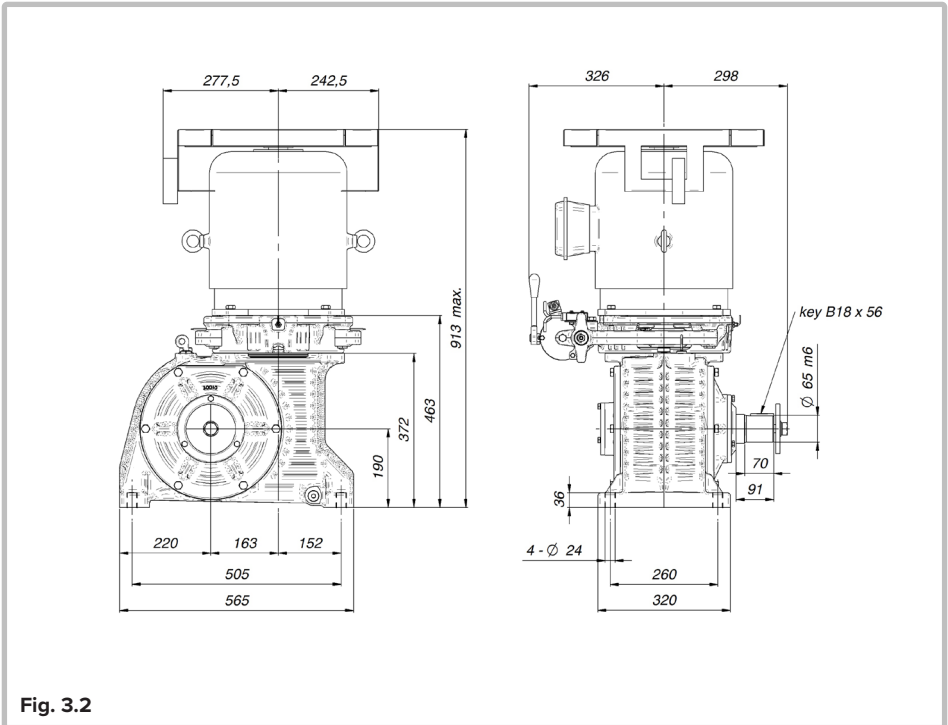

Fig. 3.2



3.5 Oil quantity

The amount of oil to fill the gearbox is shown in the following table.

Oil	
Gearbox	M93ES
Oil quantity (litres)	14.5

4. TRANSPORT AND STORAGE

4.1 Handling



Only use lifting systems and equipment with adequate lifting capacity to handle this product.

Different types of packaging can be used, depending on the size and means of transport. Unless otherwise specified, the packaging complies with the HPE guidelines.

Comply with the symbols on the packaging to prevent damage to property or personal injury. Here are the meanings of the symbols that may appear on the packaging.



Keep dry



Handle with care



Attachment point



Upper side



Do not use hooks



Keep away from heat sources



Fragile



Center of gravity

For lifting, use the two eyebolts on the side of the motor

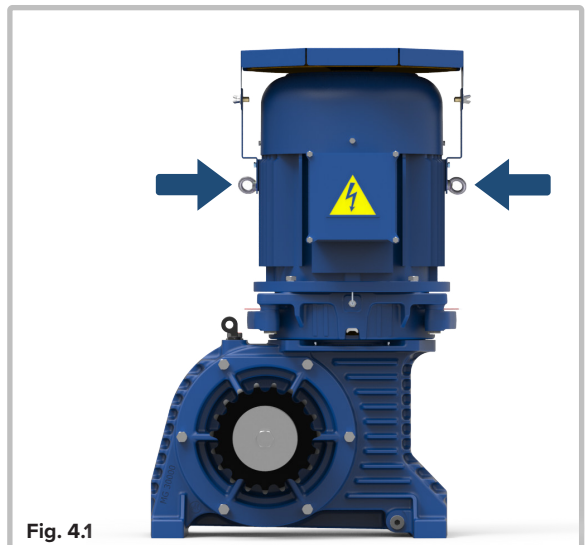

Fig. 4.1



*Use only the specified eyebolts to handle the unit.
Do not use the threaded holes on the shaft ends to screw in eyebolts or other fastening systems.*

Ropes or chains must not come into contact with the handwheel during handling operations.



The maximum slope that the machine can have during transport is 15°.

4.2 Storage

The gearbox must be stored in the position of use on a wooden base not subject to vibrations, in a covered and sheltered place.



In particular, if the unit is stored outdoors, it should be carefully covered, taking care that no moisture or other foreign matter can accumulate on it.



Supplies for special environmental conditions during transport (e.g. by ship) and storage (climate, termites, etc.) must be contractually agreed.

4.3 Standard corrosion protection

The gearbox is initially filled with synthetic oil by the manufacturer for long-term lubrication.



If oil filling has not been expressly agreed, the inside of the unit is treated with protective agents. The treatment is sufficient for normal transport conditions and for a period of 6 months until the first start.

The coating is resistant to diluted acids, alkalis, oils, solvents, seawater, tropical environments and temperatures up to 140°C.

The shaft ends are treated with anti-rust paint. They withstand seawater and tropical conditions for a period of 12 months.



*Make sure that the paint is not damaged!
Any mechanical (scratches), chemical (acids, alkalis) and thermal (sparks, welding residues) damage causes corrosion, which can affect the protective coating.*

For longer storage periods (more than 24 months) a periodic inspection is recommended and, if necessary, the restoration of the external and internal preservative treatment.



5. DESCRIPTION

5.1 General description

The M93ES Montanari is a gearbox with worm gear-crown unit equipped with a chain sprocket located on the output shaft, driven by a three-phase motor through a flexible coupling.

A dual action brake is installed on the unit to brake and stop the load.

The gearbox has exceptional characteristics of very low noise and high efficiency.

The unit is not self-locking.

All toothed parts and roller bearings are supplied properly lubricated by immersion.

5.2 Main components

The unit consists of the main groups as shown in the figure below.



Fig. 5.1

5.3 Oil plugs and indicators

Below are the symbols used to identify the breather, the oil refill, the level indicator and the drain.

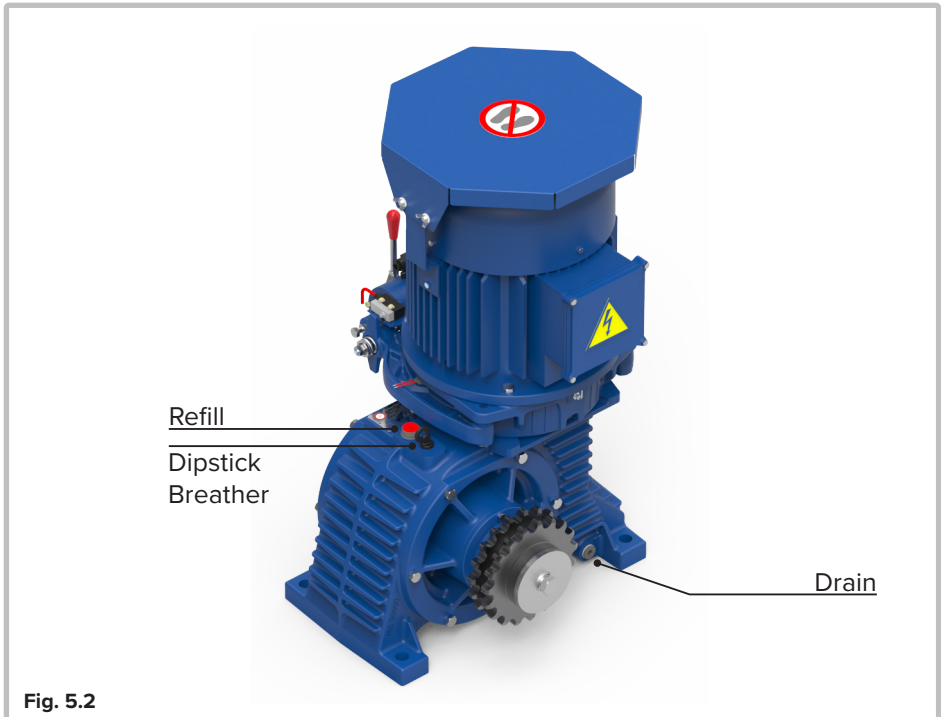

Fig. 5.2

⁽¹⁾ The vent hole can be closed during transport. In this case, the closing plug must be replaced with the breather plug supplied with the unit.

⁽²⁾ The refill plug can be fitted with a dipstick.



6. INSTALLATION

6.1 General installation information

Assembly and installation must be carried out with great care by qualified and trained personnel.

The manufacturer cannot be held responsible for damage caused by incorrect assembly or incorrect installation.

Provide sufficient space around the unit for installation to facilitate subsequent maintenance and repair work.

Before starting work, make sure that adequate lifting and handling equipment is available.

No welding work must be carried out on the unit.

The unit must not be used as a grounding point for welding operations. Toothed gears and bearings can be irreparably damaged by welding.

All fixing points specified by the manufacturer must be used.

The air supply for cooling must not be prevented. It must also be possible to check the oil level.

6.2 Installation surface

The installation surface must be uniform, level and horizontal.

The levelling tolerance is 0.2 mm.

The installation surface must be rigid and robust enough to withstand the forces involved.

6.3 Installation procedure

- Remove the anti-corrosion paint layer from the shaft and contact surfaces with a cleaning tool. The cleaning tool must not come into contact with the shaft O-rings.



Ensure proper ventilation.

Do not smoke! Danger of explosion!

- Place the unit on the installation surface and secure it.
- Fixing screws and nuts must be tightened to the prescribed torque.
- Use bolts with a minimum strength class of 8.8.
- Do not force or hit the fixings to position them; this could damage the bearings, rings, etc.

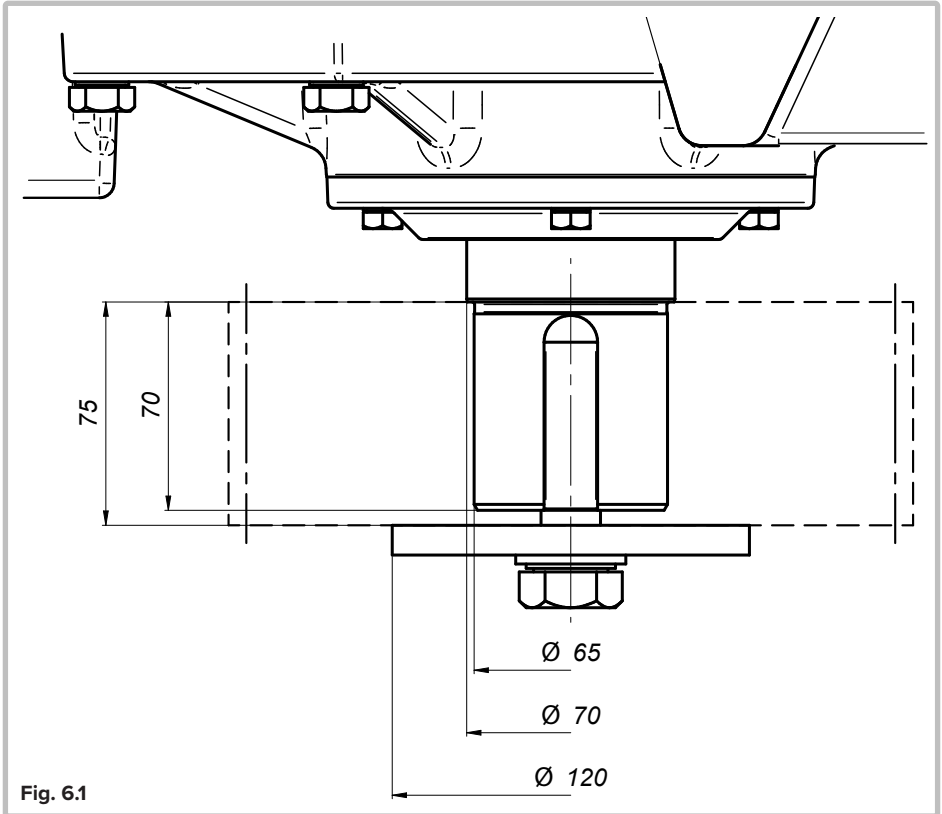

- If the pinion has not been fitted by the manufacturer, place it on the output shaft and secure it with the end plate (fig. 6.1).
- Mount the safety devices.



7. OPERATION

7.1 Preliminary operations

- Check the oil level before starting. This must be between the notches of the dipstick.

Unit supplied filled with oil

In this case, the M93ES gearbox already contains the synthetic lubricating oil (polyglycol), which was put in place by the manufacturer before shipment.

Unit supplied without oil

If the gearbox was supplied without oil filling, the unit must be filled with lubricant to get between the notches on the shaft.

The quantity of oil indicated on the plate is indicative. The lubricant table shows various suitable oil types in accordance with the manufacturer's instructions. Equivalent antifoam oils from other manufacturers may also be used. It is important to use the type of oil (synthetic or mineral) indicated on the plate.

However, the manufacturer cannot guarantee the complete suitability of the selected lubricant.

The oil viscosity must also be as indicated on the plate.

7.2 Connections

Connect the motor, brake, and monitoring devices.

The connection must be made by qualified personnel in accordance with the applicable safety regulations. Installation and operation requirements and current national and international standards must be met.

7.3 Additional components

If third party additional components or options are installed, please refer to the information in the respective separate documentation provided.

7.4 General operation information

When operating the M93ES unit, be sure to check that the following situations do not occur:

- Excessive operating temperature.
- Excessive and unusual noise.
- Oil leaks.

If any irregularity occurs during operation, turn off the power immediately. Identify the cause of the malfunction by using the table in Chap. 8, containing a list of possible problems, their causes and suggested remedies.



If the cause of the malfunction cannot be identified, or if the unit has been repaired using the means available, you should contact one of our service centres for a specialised service.



8. TROUBLESHOOTING

8.1 General information



Problems and malfunctions occurring during the warranty period, which are not precisely identified or which require work on the unit, must be referred to the manufacturer's Customer Service department.

Montanari cannot guarantee or be held responsible for unauthorized operations on the unit, improper use, modifications made without its consent or the use of non-genuine spare parts.



When repairing problems or malfunctions, the unit must be put out of service in order to prevent unintentional start-up. Place a warning sign on the starting switch.

The Montanari M93ES gearbox is not self-locking.

8.2 Problems, causes and solutions

Diagnostic table		
Problems	Causes	Solutions
Changes in unit noise.	Damaged gear teeth. Excessive clearance of bearings. Damaged bearings. Loose fixings.	Contact customer service. Tighten screws and nuts to the prescribed torque.
Too high operating temperature.	Oil level in unit too high or too low. Oil too old. Contaminated oil. Damaged bearings.	Check the oil level at room temperature and adjust if necessary. Change oil. Contact customer service.
Oil leakage from the unit.	Defective radial O-rings on the shaft.	Replace the shaft O-rings.

9. MAINTENANCE AND REPAIR

9.1 General information



All maintenance and repair operations must be carried out with care and only by qualified and trained personnel.

Compliance with the inspection and maintenance intervals is part of the conditions for the validity of the warranty.

9.2 Maintenance table

The following table shows the scheduled maintenance operations.

Maintenance table		
Intervention	Interval	Notes
Unit temperature check.	Monthly.	Allowed up to 80° on the unit.
Check for unusual noises.	Monthly.	
Oil level check.	Monthly.	The level must be between the notches of the dipstick.
Leakage check on the unit.	Monthly.	
First oil change from start up.	After about 1000 (300) work hours, but within 5 years (18 months).	
Following oil changes.	After about 6000 (2000) hours of work, but within 5 years (18 months).	
Cleaning the breather screw.	Simultaneously with the oil change.	
Gearbox cleaning.	Simultaneously with the oil change.	



Maintenance table

Intervention	Interval	Notes
Checking the tightening of bolts and nuts.	Simultaneously with the oil change.	

9.3 Description of maintenance activities

Changing oil

When changing oil, always use the same type of lubricant as that contained in the M93ES. Do not mix different types of oil, or oils from different manufacturers. Do not mix synthetic oils with mineral oils or other types of synthetic oil.



TIP

Oil should be drained immediately after switching off the unit while it is still hot. Drainage must last long enough for oily deposits, abraded metal and other oily residues to flow out.

If iridescent particles of abraded bronze appear in the oil, this should not be considered a problem.



Risk of burning with hot oil drained from the unit. Wear protective gloves to prevent contact.

Immediately remove any oil spills with a binding agent.

The gear oil must never be mixed with other substances.

Washing with paraffin or other solvents is not permitted, as traces of these substances may remain inside the unit.

Cleaning the breather plug

The breather screw must be cleaned if dust deposits on it. To clean it, remove it, wash it with petrol or similar liquids, and dry it.

Alternatively, it can be cleaned by blowing compressed air.

Cleaning the unit

Stop the unit and put it out of service to prevent unintentional start-up. Place a warning sign on the starting switch.

Remove dirt on the unit with a hard brush.

Remove corrosion signs.

The unit must not be cleaned with high pressure washing equipment.

Checking the tightening of bolts and nuts.

Stop the unit and put it out of service to prevent unintentional start-up. Place a warning sign on the starting switch.

Check the tightness of all fastening bolts and nuts with a torque wrench. The screws and nuts must be tightened to the prescribed torque. The tightening torque is indicated in the following table.

Bolt tightening torques (class 8.8)						
Thread	M8	M10	M12	M16	M20	M24
Tightening torque (Nm)	25	49	86	210	410	710

9.4 Lubricants

For its units, Montanari only approves CLP oils that contain ingredients according to DIN 51517-3, for increased corrosion protection, durability and reduced wear in mixed friction zones.

We recommend that customers use one of the lubricants listed in the table, taking into account the viscosity grade specified on the plate.



The use of lubricants that do not meet the above requirements may invalidate the product warranty. Every oil producer or supplier is responsible for the quality of his product.

If an oil of incorrect viscosity or an oil other than that recommended in these instructions is used, the operator is responsible for this choice.

In this case, in order to minimize the technical risk, we recommend the use of a higher quality CLP oil that is accompanied by a declaration of suitability from the manufacturer.

Always comply with the information on the plates and written instructions for the gearmotors.

Types of oil

- Mineral oils
- Synthetic oils



Synthetic oils have a wider temperature range and a higher viscosity index (i.e. a flatter viscosity-temperature gradient) compared with mineral oils. Approximate values for temperature range:

- Mineral oils from about -10°C to $+90^{\circ}\text{C}$ (short term $+100^{\circ}\text{C}$)
- Polyglycol from about -20°C to $+100^{\circ}\text{C}$ (short term $+110^{\circ}\text{C}$)

Note: The maximum and minimum utilisation temperature (flash point, pour point) of certain gear lubricants may differ significantly from that of the figures shown. For these and other data and properties relating to lubricants, refer to the technical data sheet published by the oil manufacturer.

10. SPARE PARTS

10.1 General information



By keeping the main spare parts and wear parts in stock, the unit can always be used.

10.2 How to order spare parts

Refer to the following tables to order spare parts.

The manufacturer guarantees only genuine spare parts supplied by him.

Spare parts or accessories not supplied by the manufacturer have not been tested or approved. The use of these parts can therefore compromise certain characteristics of the gearbox and expose it to active and passive safety risks.



The manufacturer will not assume any responsibility and will not recognize warranty for damage caused by spare parts and accessories not supplied by the manufacturer himself.

Consider that some components often have special characteristics of production and supply, and only the manufacturer provides spare parts that fully meet the current state of technical development, as well as current standards.

When ordering spare parts, always specify:

- Order no.
- Part code
- Description
- Quantity

10.3 How to identify spare parts

Here are the tables for the identification of spare parts.



10.4 Table 1 - Motor

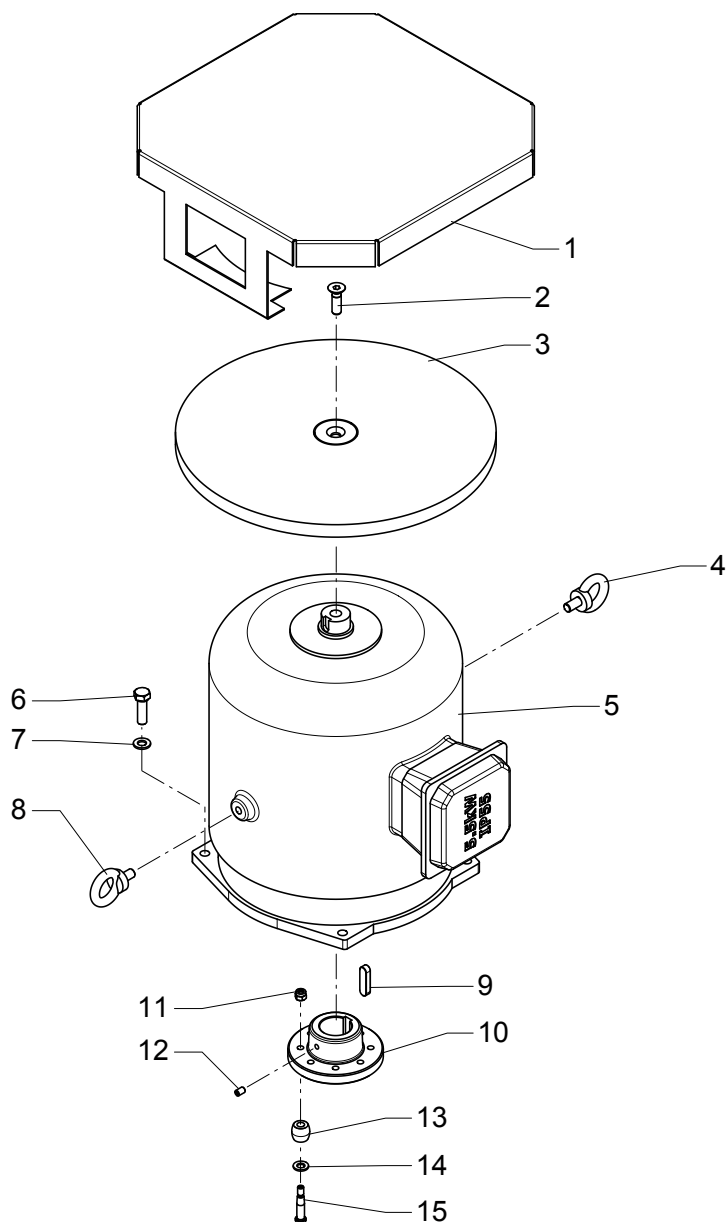

10.5 Table 2 - Brake

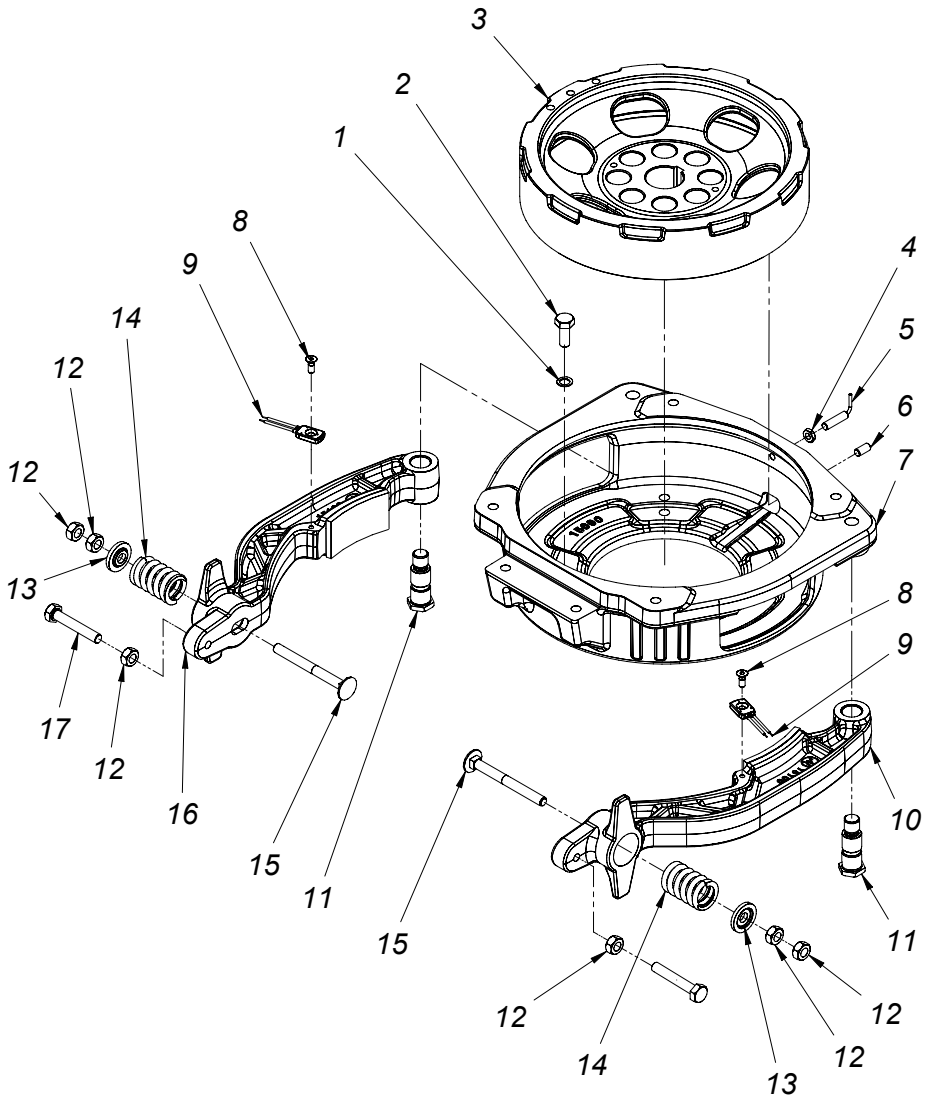



10.6 Table 3 - Magnet

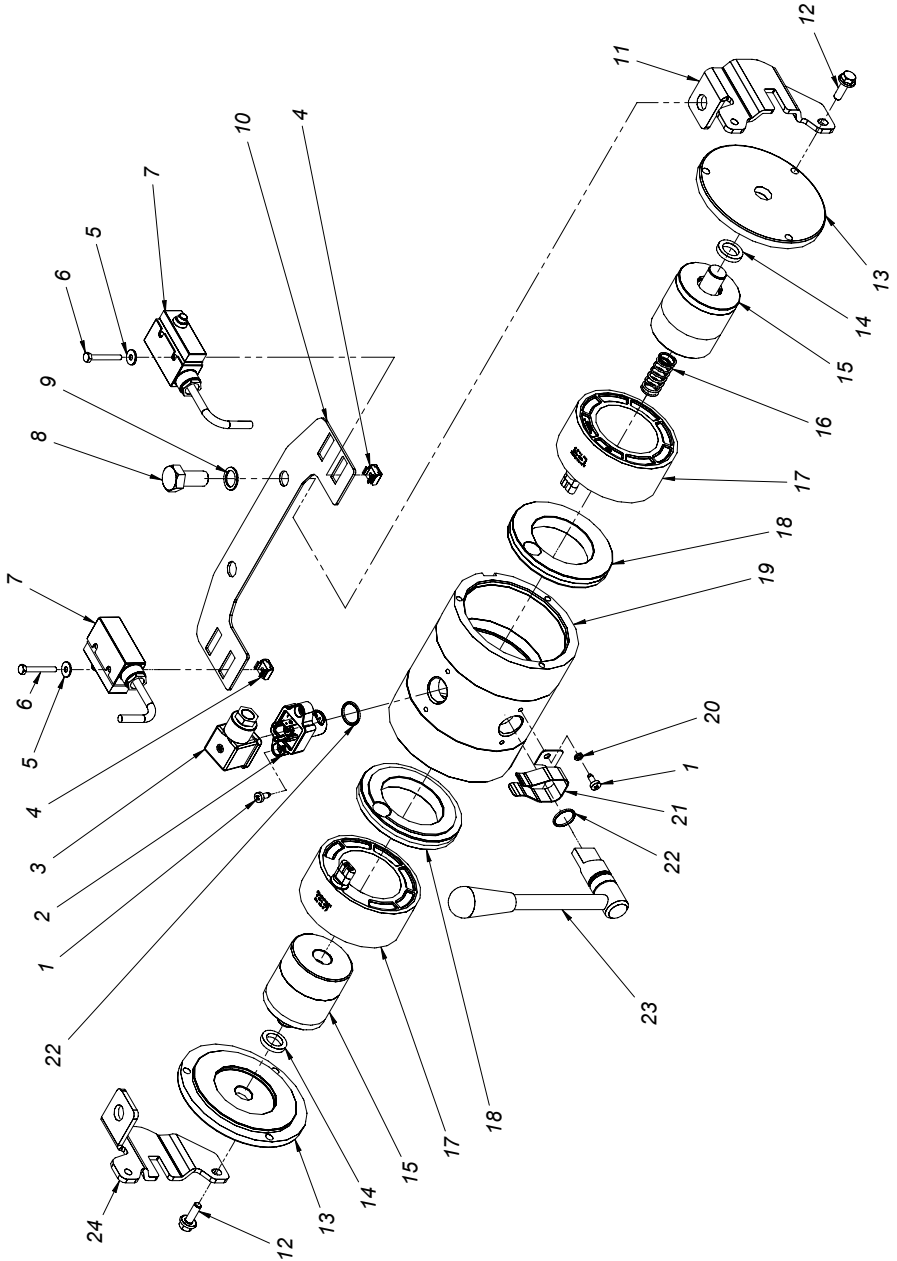

10.7 Table 4 - Slow Shaft

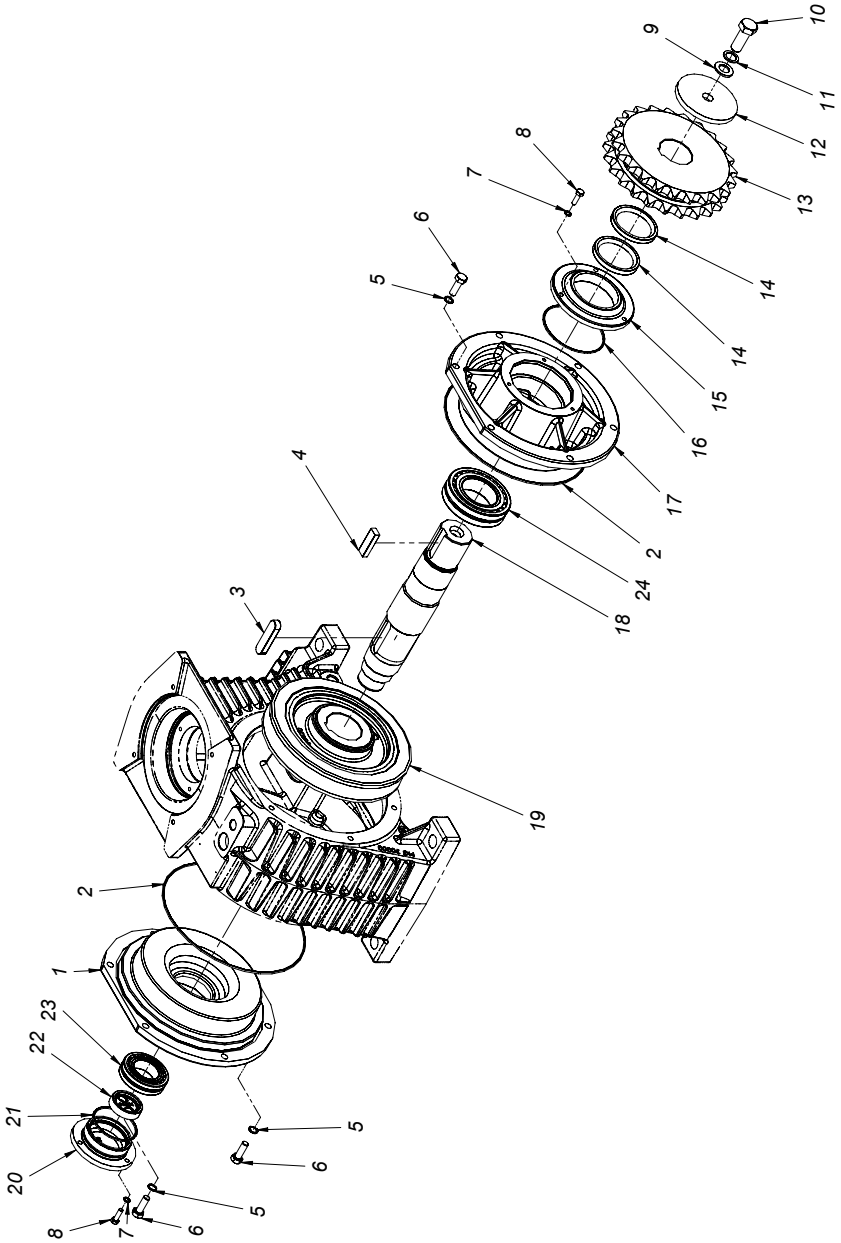



10.8 Table 5 - Worm Shaft

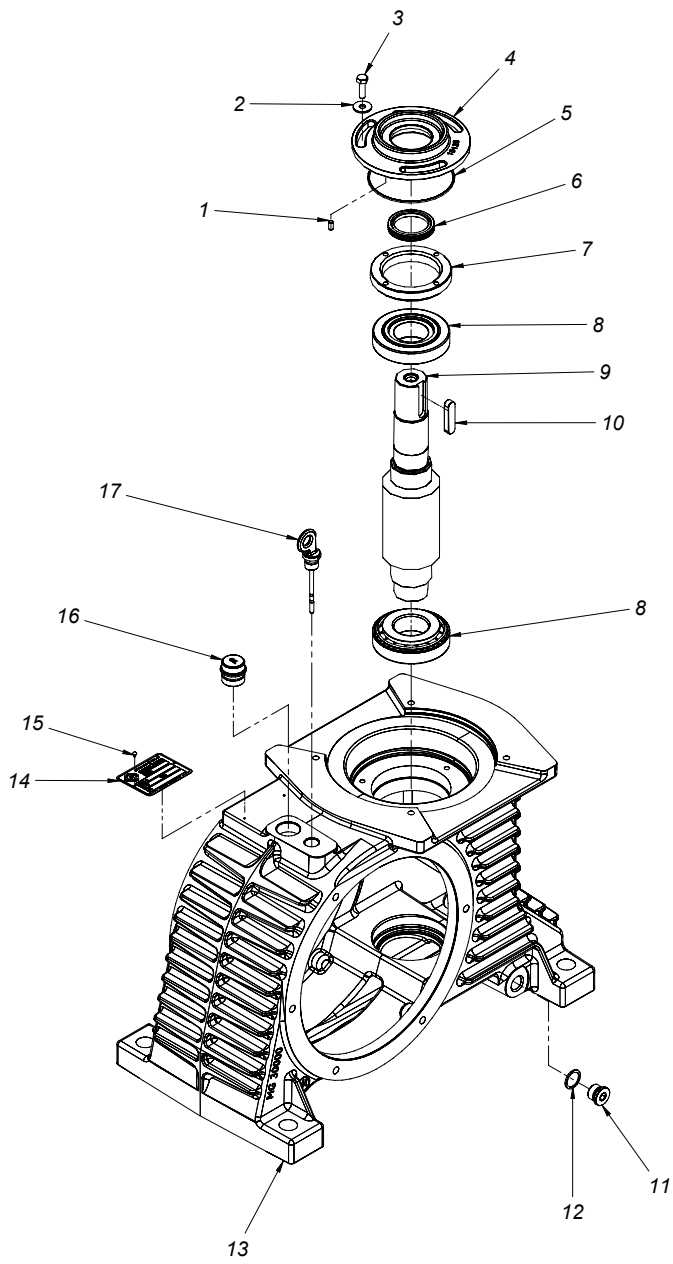



Montanari Group

**GEARLESS&GEARBOX
TRACTION MACHINES**

MONTANARI GIULIO & C. S.r.l

**DECLARATION OF INCORPORATION OF PARTLY
COMPLETED MACHINERY**

**(Directive 2006/42/EC, Annex II, par. B.)
Escalator gearboxes**

Manufacturer:

**Montanari Giulio & C. S.r.l.
Via Bulgaria no. 39, 41122 Modena**

Models concerned by this declaration:

M73ES - M93ES - ME165 - ME190; complete with electric motor and electromechanical brake.

The relevant essential safety requirements have been applied and complied with and the relevant technical documentation has been compiled in accordance with Annex VII B.

The partly completed machines mentioned also comply with the following directives: 2014/30/EU, 2014/35/EU

The machines mentioned are suitable for use as escalator machines and moving walkways. They therefore comply with the following standards where applicable:

EN 115-1:2010

EN 115-1:2017

IEC CEI EN 600034

Montanari Giulio & C. S.r.l. undertakes to forward the relevant information on the partly completed machinery mentioned in response to reasoned requests from the national authorities.

It is not permitted to put the mentioned partly completed machinery into service until the machinery into which it is to be incorporated has been identified and declared to comply with the conditions of Directive 2006/42/EC and/or the national legislation transposing it, i.e. until the machinery referred to in this declaration forms a single unit with the final machinery.

Violation of the provisions of this document will result in the immediate decay of all product warranties.

Drafting:

Stefano Bertoni – Technical Manager

Signature:

Massimo Montanari - Legal Representative

Modena, 01/04/2019

Montanari Giulio & C. srl
Via Bulgaria/39 - 41122 MODENA-Italy
Tel. +39 059 45 36 11
Cod. Fisc. e P. IVA 01047490368

Montanari Giulio & C. Srl - Montanari Group Headquarter

Via Bulgaria, 39 - 41122 - Modena - Italia

Tel: +39 059 453611 - Fax: +39 059 315890 - info@montanarijulio.com

www.montanarijulio.com



Montanari Group
GEARLESS&GEARBOX
TRACTION MACHINES

MONTANARI GROUP HEADQUARTERS
Montanari Giulio & C. S.r.l.

Via Bulgaria, 39 - 41122 - Modena - Italy

Phone: +39 059 453611 - Fax: +39 059 315890 - info@montanarigiulio.com

www.montanarigiulio.com

