

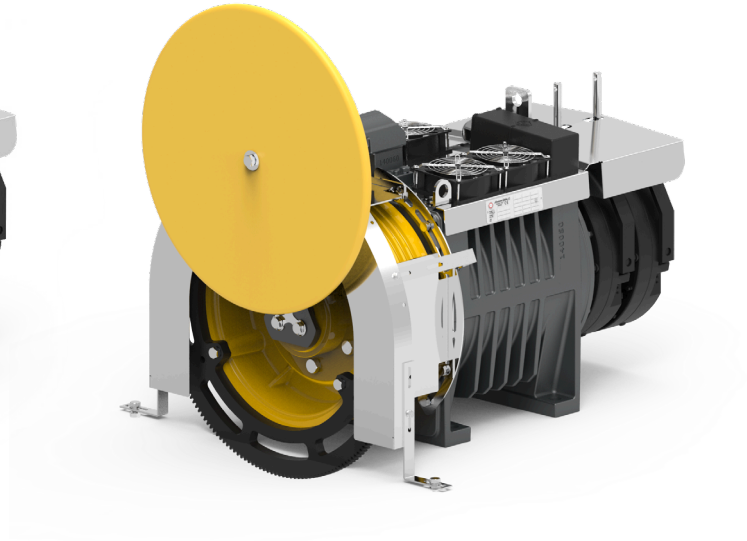

Montanari Group
 GEARLESS&GEARBOX
 TRACTION MACHINES

无齿轮
 GEARLESS

MDX36S

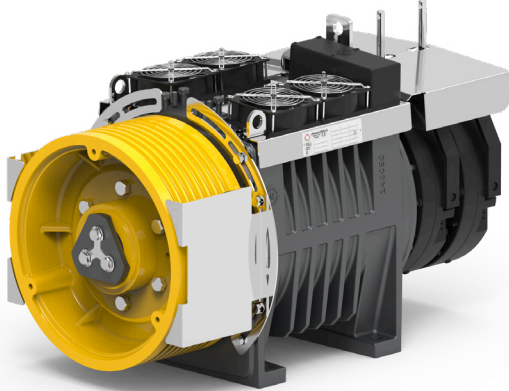

主轴静载
 Static Load

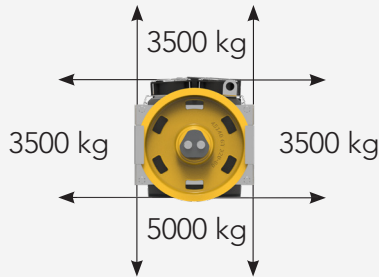

自重
 Weight

472 kg

额定扭矩 Nominal Torque	阻转转矩 Short circuited torque	级数 Poles	编码器 Encoder
Nm	Nm		
850 S5 - 40% ED 180 s/h	900	16	ERN1387 ECN1313 EI53C9.25 TS5213N2531
制动器 Brake			
EMFR DC110V/2X2.03A [2X1400Nm]			



		绳槽 Ropes			尺寸 Dimensions
曳引轮直径 ØD	宽度 F	绳径 Ø	绳槽数 n°	槽距 Pitch	A
mm	mm	mm	n°	mm	mm
320	180	8	3 - 10	17	153
400		10			

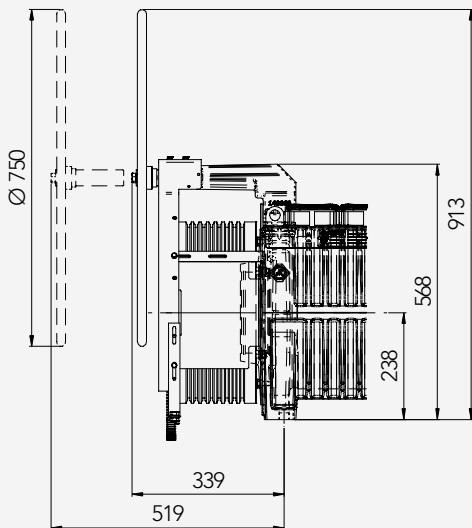
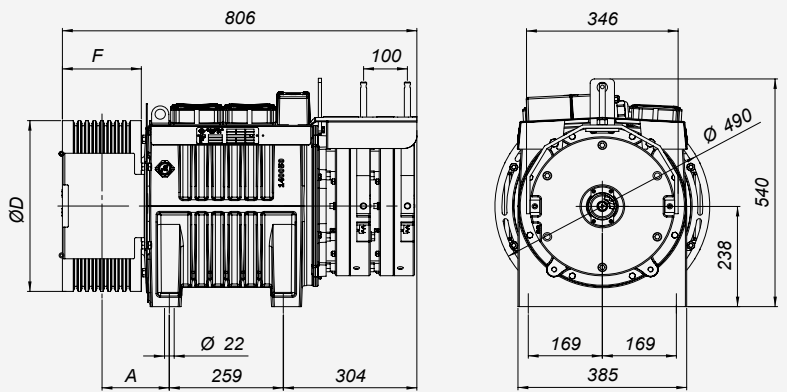
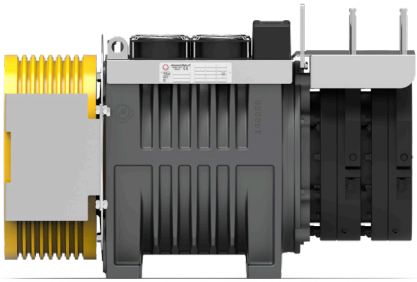

有机房使用
Machine Room Use

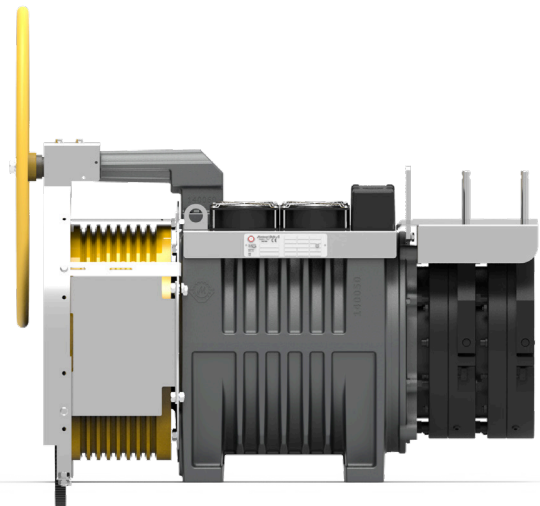

2:1	额定载重 Load		∅	绳槽 Ropes	槽距 Pitch	额定扭矩 Torque	额定功率 Power	额定转速 RPM	额定频率 Freq.	额定电流 Current 380V
	kg	m/s	mm	max	mm	Nm	kW	RPM	Hz	A
1350	0,63	400	10x∅10	17	885	5,6	60	8,0	18,2	
	1,0	400	10x∅10	17	885	8,9	95	12,7	25,6	
	1,6	400	10x∅10	17	885	14,2	153	20,4	44,3	
	2,0	400	10x∅10	17	885	17,7	191	25,5	44,3	
	2,5	400	10x∅10	17	885	22,1	239	31,8	59,0	
	3,0	400	10x∅10	17	885	26,6	286	38,2	59,0	
1600	0,63	320	10x∅8	17	812	6,4	75	10,0	22,9	
	1,0	320	10x∅8	17	812	10,2	119	15,9	26,7	
	1,6	320	10x∅8	17	812	16,2	191	25,5	41,1	
	2,0	320	10x∅8	17	812	20,3	239	31,8	41,1	
	2,5	320	10x∅8	17	812	25,4	298	39,8	55,4	

