

自重  
Weight | 539 kg

额定扭矩 Nominal Torque	极数 Poles	编码器 Encoder
Nm		
<b>1050</b> <b>S5 - 40% ED</b> <b>180 s/h</b>	16	ERN1387 ECN1313 EI53C9.25 TS5213N2531
制动器 <b>Brake</b>		
EMFR1400 DC110V/2X2.03A[2X1400Nm]		

		绳槽 Ropes			尺寸 Dimensions
曳引轮直径 ØD	宽度 F	绳径 Ø	绳槽数 n°	槽距 Pitch	A
mm	mm	mm	max	mm	mm
320	180	8	10	17	153
400		10			

- 1 - 数据如有更改，恕不另行通知  
1 - Data are subject to change without prior notice.  
2 - 我们能够提供带电源线和不带电源线两种配置的机器  
2 - We are able to offer machines with both power cable and no power cable configurations.

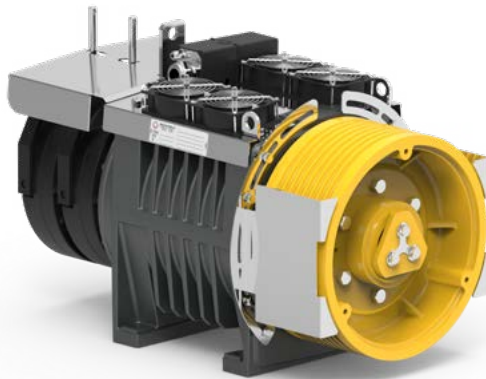

2:1	额定载重 Load	额定速度 Speed	∅	绳槽 Ropes	槽距 Pitch	额定扭矩 Torque	额定功率 Power	额定转速 RPM	额定频率 Freq.	额定电流 Current 380V
	kg	m/s	mm	max	mm	Nm	kW	RPM	Hz	A
1600	0,63	0,63	320	10x∅8	17	812	6,4	75	10,0	16,2
	0,63	400	10x∅10	17	1016	6,4	60	8,0	20,3	
	1,0	320	10x∅8	17	812	10,2	119	15,9	23,6	
	1,0	400	10x∅10	17	1016	10,2	95	12,7	29,5	
	1,6	320	10x∅8	17	812	16,2	191	25,5	44,9	
	1,6	400	10x∅10	17	1016	16,3	153	20,4	41,6	
	2,0	320	10x∅8	17	812	20,3	239	31,8	44,9	
	2,0	400	10x∅10	17	1016	20,3	191	25,5	51,6	
	2,5	320	10x∅8	17	812	25,4	298	39,8	53,4	
	2,5	400	10x∅10	17	1016	25,4	239	31,8	56,1	
	3,0	320	10x∅8	17	812	30,5	358	47,7	65,8	
	3,0	400	10x∅10	17	1016	30,5	286	38,2	66,7	
2000	0,63	0,63	320	10x∅8	17	997	7,9	75	10,0	19,9
	1,0	320	10x∅8	17	997	12,5	119	15,9	29,0	
	1,6	320	10x∅8	17	997	19,9	191	25,5	55,1	
	2,0	320	10x∅8	17	997	24,9	239	31,8	65,5	
	2,5	320	10x∅8	17	997	31,2	298	39,8	80,7	

