

额定扭矩 Nominal Torque	阻转转矩 Short circuited torque	级数 Poles	编码器 Encoder
Nm	Nm		
1050 S5 - 40% ED 180 s/h	1250	16	ERN1387 ECN1313 EI53C9.25 TS5213N2531
制动器 Brake			
EMFR DC110V/2X2.03A [2X1400Nm]			

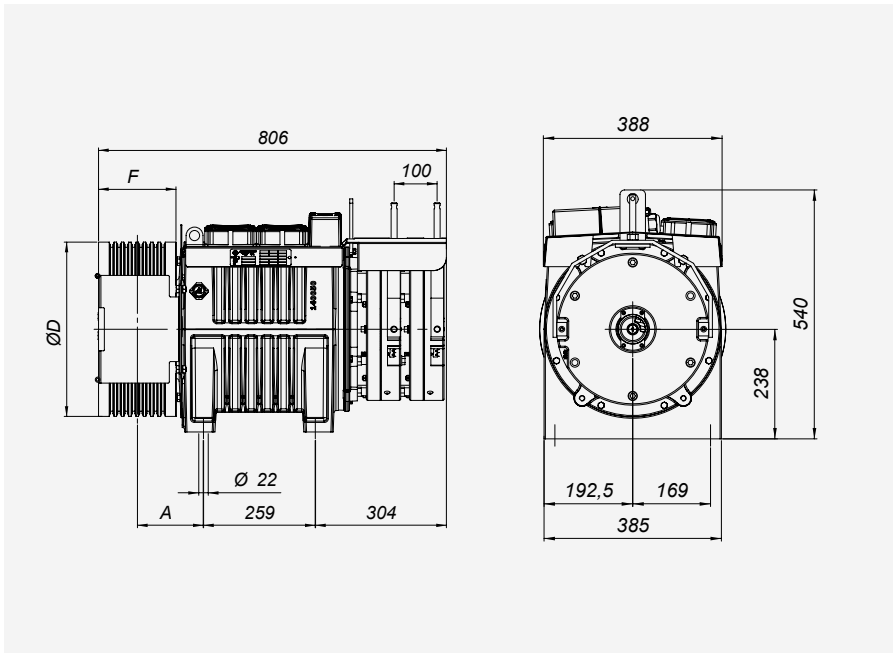

		绳槽 Ropes			尺寸 Dimensions
曳引轮直径 ØD	宽度 F	绳径 Ø	绳槽数 n°	槽距 Pitch	A
mm	mm	mm	n°	mm	mm
320	180	8	3 - 10	17	153
400		10			

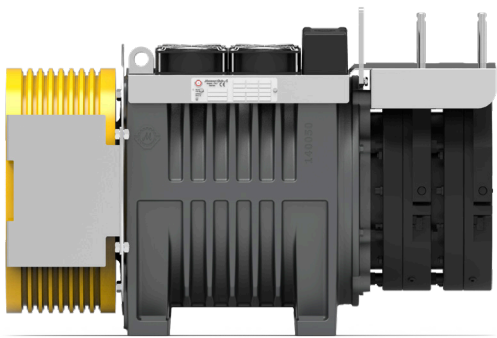

有机房使用
Machine Room Use

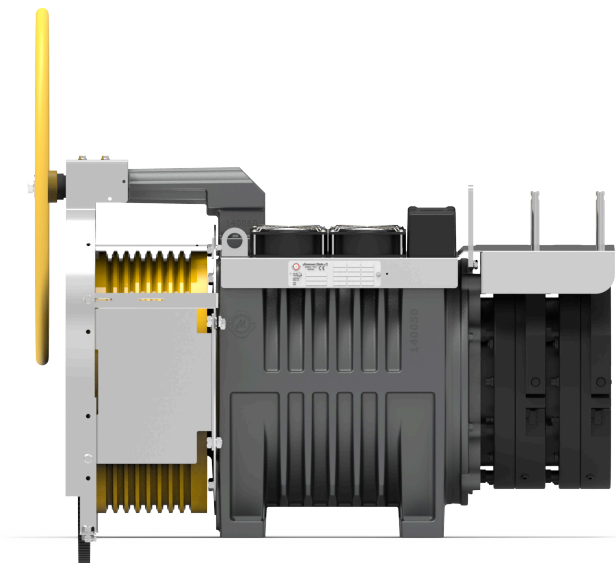
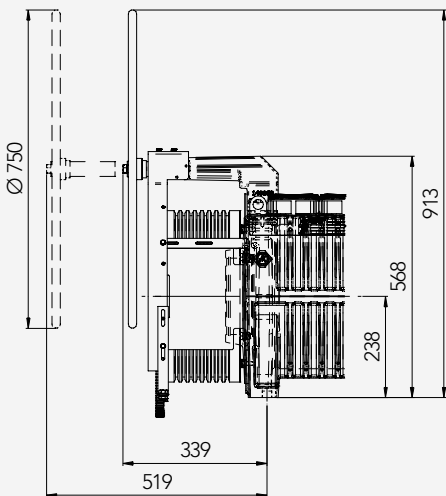

额定载重 Load		Ø	绳槽 Ropes	槽距 Pitch	额定扭矩 Torque	额定功率 Power	额定转速 RPM	额定频率 Freq.	额定电流		
									Current 380V		
kg	m/s	mm	max	mm	Nm	kW	RPM	Hz	A		
2:1	1600	0,63	320	10xØ8	17	812	6,4	75	10,0	16,2	
		0,63	400	10xØ10	17	1016	6,4	60	8,0	20,3	
		1,0	320	10xØ8	17	812	10,2	119	15,9	23,6	
		1,0	400	10xØ10	17	1016	10,2	95	12,7	29,5	
		1,6	320	10xØ8	17	812	16,2	191	25,5	44,9	
		1,6	400	10xØ10	17	1016	16,3	153	20,4	41,6	
		2,0	320	10xØ8	17	812	20,3	239	31,8	44,9	
		2,0	400	10xØ10	17	1016	20,3	191	25,5	51,6	
		2,5	320	10xØ8	17	812	25,4	298	39,8	53,4	
		2,5	400	10xØ10	17	1016	25,4	239	31,8	56,1	
		3,0	320	10xØ8	17	812	30,5	358	47,7	65,8	
		3,0	400	10xØ10	17	1016	30,5	286	38,2	66,7	
		2000	0,63	320	10xØ8	17	997	7,9	75	10,0	19,9
			1,0	320	10xØ8	17	997	12,5	119	15,9	29,0
1,6	320		10xØ8	17	997	19,9	191	25,5	55,1		
2,0	320		10xØ8	17	997	24,9	239	31,8	65,5		
2,5	320		10xØ8	17	997	31,2	298	39,8	80,7		

