

自重  
Weight 677 kg

额定扭矩 Nominal Torque	阻转转矩 Short circuited torque	级数 Poles	编码器 Encoder
Nm	Nm		
<b>1650</b> <b>S5 - 40% ED</b> <b>180 s/h</b>	1900	16	ERN1387 ECN1313 EI53C9.25 TS5213N2531
<b>制动器</b> <b>Brake</b>			
RSR1500 [2x1700Nm] 2X165W - 207V <sub>DC</sub>			

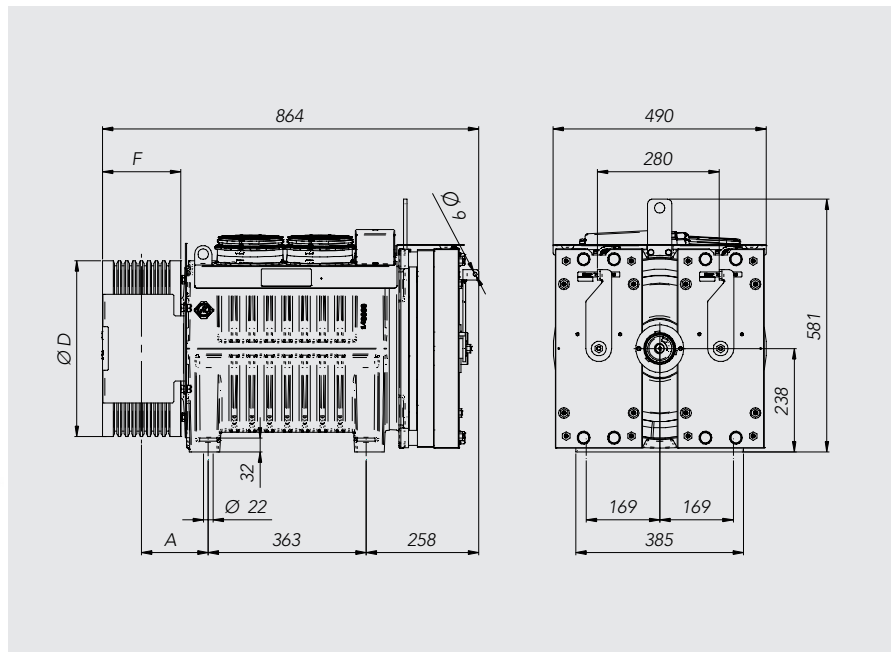

		绳槽 Ropes			尺寸 Dimensions
曳引轮直径 ØD	宽度 F	绳径 Ø	绳槽数 n°	槽距 Pitch	A
mm	mm	mm	n°	mm	mm
320	180	8	3 - 10	17	153
400		10			

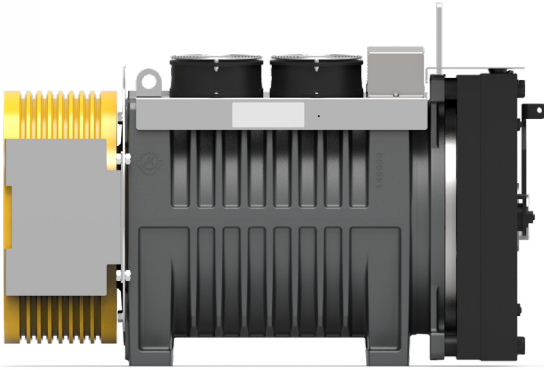

有机房使用  
Machine Room Use

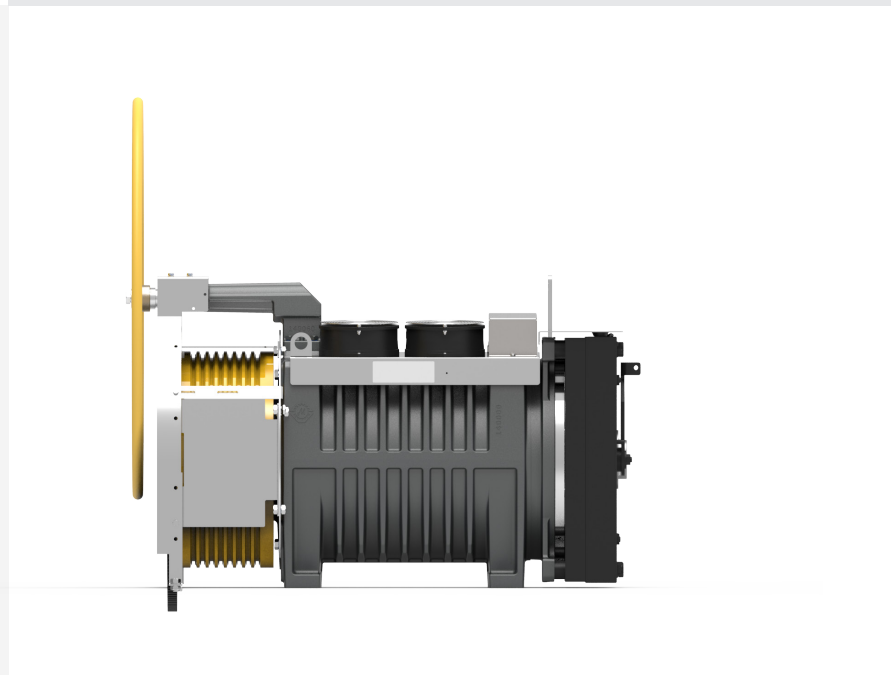
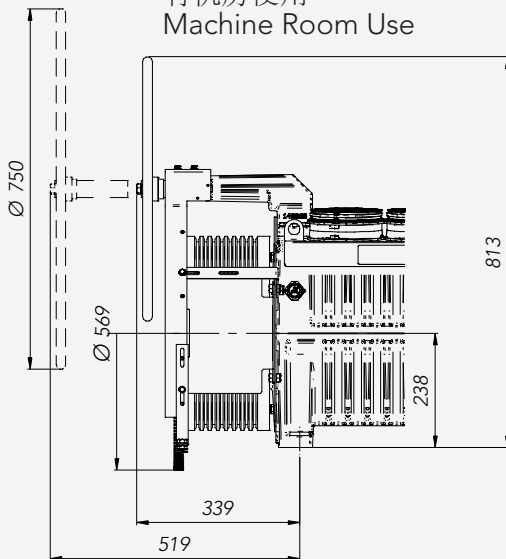

额定载重 Load		∅	绳槽 Ropes	槽距 Pitch	额定扭矩 Torque	额定功率 Power	额定转速 RPM	额定频率 Freq.	额定电流 Current 380V		
	kg	m/s	mm	max	mm	Nm	kW	RPM	Hz	A	
<b>2:1</b>	2500	0,63	320	10x∅8	17	1228	9,7	75	10,0	31,8	
		0,63	400	10x∅10	17	1535	9,7	60	8,0	39,8	
		1,0	320	10x∅8	17	1228	15,4	119	15,9	35,6	
		1,0	400	10x∅10	17	1535	15,4	95	12,7	39,8	
		1,6	320	10x∅8	17	1228	24,6	191	25,5	51,5	
		1,6	400	10x∅10	17	1535	24,6	153	20,4	64,4	
		2,0	320	10x∅8	17	1228	30,7	239	31,8	64,4	
		2,0	400	10x∅10	17	1535	30,7	191	25,5	64,4	
		2,5	320	10x∅8	17	1228	38,4	298	39,8	85,7	
		2,5	400	10x∅10	17	1535	38,4	239	31,8	80,5	
		3,0	400	10x∅10	17	1535	46,1	286	38,2	107,1	
		3000	0,63	320	10x∅8	17	1459	11,5	75	10,0	37,8
			1,0	320	10x∅8	17	1459	18,2	119	15,9	42,3
			1,6	320	10x∅8	17	1459	29,2	191	25,5	61,2
			2,0	320	10x∅8	17	1459	36,5	239	31,8	76,5
			2,5	320	10x∅8	17	1459	45,6	298	39,8	101,8

