

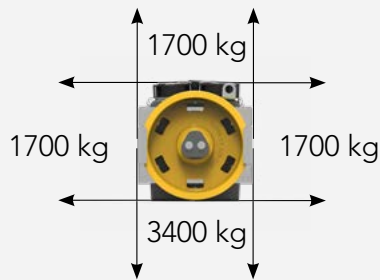

主轴静载  
Static Load



自重  
Weight

240 kg

额定扭矩 Nominal Torque	极数 Poles	编码器 Encoder
Nm		
<b>630</b> <b>S5 - 40% ED</b> <b>180 s/h</b>	16	ERN1387 ECN1313 EI53C9.25 TS5213N2531
<b>制动器</b> <b>Brake</b>		
EMFS DC110V/2X1.0A [2X650Nm]		

 曳引轮直径 ØD		绳槽 Ropes			尺寸 Dimensions			
		宽度 F	绳径 Ø	绳槽数 n°	槽距 Pitch	A	B	C
mm		mm	max	mm	mm	mm	mm	mm
240	105	6,5	10	9,5	679	262	362	74
320	114	8	9	12		342		

1 - 数据如有更改，恕不另行通知

1 - Data are subject to change without prior notice.

2 - 我们能够提供带电源线和不带电源线两种配置的机器

2 - We are able to offer machines with and without power cable configurations.

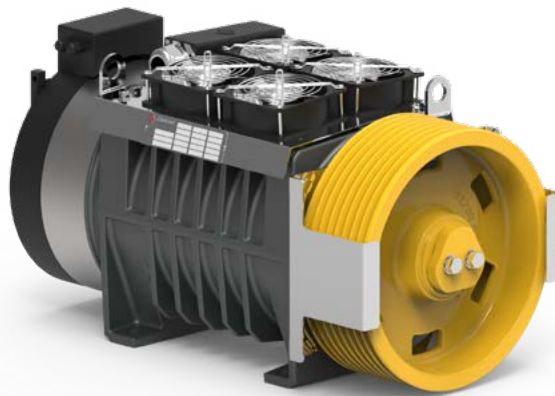

2:1	额定载重 Load		∅	绳槽 Ropes	槽距 Pitch	额定扭矩 Torque	额定功率 Power	额定转速 RPM	额定频率 Freq.	额定电流 Current 220V	额定电流 Current 380V
	kg	m/s	mm	max	mm	Nm	kW	RPM	Hz	A	A
1150	0,63	320	8x∅8	12	584	4,60	75	10,0	37,1	20,4	
	1,0	320	8x∅8	12	584	7,30	119	15,9	37,1	20,4	
	1,5	320	8x∅8	12	584	10,95	179	23,9	48,2	29,7	
	1,75	320	8x∅8	12	584	12,77	209	27,9	68,6	29,7	
	2,00	320	8x∅8	12	584	14,60	239	31,8	68,6	37,1	
	2,50	320	8x∅8	12	584	18,25	298	39,8	68,7	37,1	
1200	0,63	320	9x∅8	12	523	4,12	75	10,0	35,2	19,3	
	1,0	320	9x∅8	12	523	6,54	119	15,9	35,2	19,3	
	1,5	320	9x∅8	12	609	11,43	179	23,9	71,6	31,0	
	1,75	320	9x∅8	12	609	13,33	209	27,9	71,6	31,0	
	2,0	320	9x∅8	12	609	15,23	239	31,8	71,6	38,7	
	2,5	320	9x∅8	12	609	19,04	298	39,8	83,2	50,3	
1500	0,63	240	10x∅6.5	9,5	571	6,00	100	13,4	47,2	25,4	
	1,0	240	10x∅6.5	9,5	571	9,52	159	21,2	47,2	25,4	
	1,5	240	10x∅6.5	9,5	571	14,28	239	31,8	67,1	36,3	
	1,75	240	10x∅6.5	9,5	571	16,66	279	37,1	67,1	36,3	
	2,00	240	10x∅6.5	9,5	571	19,04	318	42,4	78,0	47,2	

