

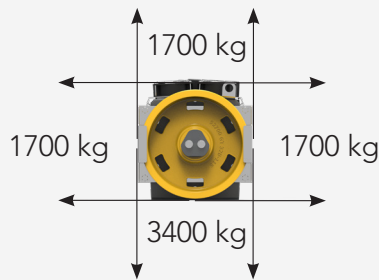

主轴静载
Static Load



自重
Weight

220 kg

额定扭矩 Nominal Torque	阻转转矩 Short circuited torque	级数 Poles	编码器 Encoder
Nm	Nm		
530 S5 - 40% ED 180 s/h	600	16	ERN1387 ECN1313 EI53C9.25 TS5213N2531
制动器 Brake			
EMFR DC110V/2.3A[2X600Nm]			

		绳槽 Ropes			尺寸 Dimensions				
		曳引轮直径 ØD	宽度 F	绳径 Ø	绳槽数 n°	槽距 Pitch	A	B	C
mm		mm	mm	mm	mm	mm	mm	mm	mm
240	105	6,5	10	9,5	679	262	362	74	
320	114	8	6-7	12		342			

1 - 数据如有更改，恕不另行通知

1 - Data are subject to change without prior notice.

2 - 我们能够提供带电源线和不带电源线两种配置的机器

2 - We are able to offer machines with and without power cable configurations.

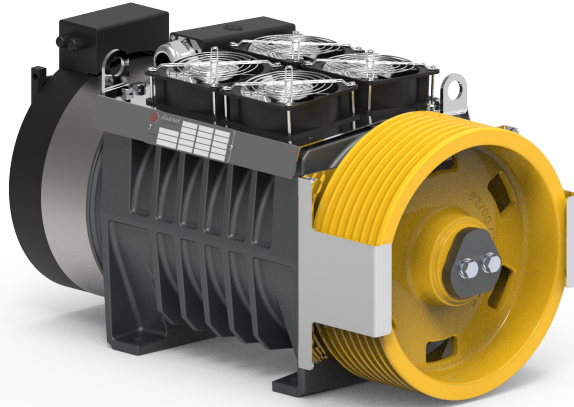

	额定载重 Load		∅	绳槽 Ropes	槽距 Pitch	额定扭矩 Torque	额定功率 Power	额定转速 RPM	额定频率 Freq.	额定电流 Current 220V	额定电流 Current 380V
	kg	m/s	mm	max	mm	Nm	kW	RPM	Hz	A	A
2:1	800	0,63	320	6x∅8	12	349	2,75	75	10,0	24,4	10,2
		1,0	320	6x∅8	12	406	5,08	119	15,9	28,4	11,9
		1,5	320	6x∅8	12	406	7,62	179	23,9	34,5	15,5
		1,75	320	6x∅8	12	406	8,89	209	27,9	46,0	19,7
		2,0	320	6x∅8	12	406	10,16	239	31,8	46,0	26,1
	1000	2,5	320	6x∅8	12	406	12,70	298	39,8	59,0	29,2
		0,63	320	7x∅8	12	436	3,43	75	10,0	30,4	14,3
		1,0	320	7x∅8	12	436	5,45	119	15,9	30,4	14,3
		1,5	320	7x∅8	12	508	9,52	179	23,9	43,1	22,8
		1,75	320	7x∅8	12	508	11,11	209	27,9	57,5	25,6
	1200	2,0	320	7x∅8	12	508	12,70	239	31,8	57,5	32,3
		2,5	320	7x∅8	12	508	15,87	298	39,8	73,8	36,5
		0,63	240	10x∅6.5	9,5	457	4,80	100	13,4	38,8	20,5
		1,0	240	10x∅6.5	9,5	457	7,62	159	21,2	38,8	20,5
		1,5	240	10x∅6.5	9,5	457	11,43	239	31,8	66,4	31,9
	1,75	240	10x∅6.5	9,5	457	13,33	279	37,1	66,4	31,9	
	2,0	240	10x∅6.5	9,5	457	15,23	318	42,4	66,4	38,8	

