

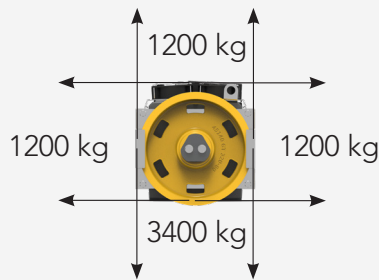

主轴静载
Static Load



自重
Weight

180 kg

| 额定扭矩 Nominal Torque | 阻转转矩 Short circuited torque | 级数 Poles | 编码器 Encoder |
|--|--------------------------------|-------------|--|
| Nm | Nm | | |
| 385 S5 - 40% ED 180 s/h | 450 | 16 | ERN1387 ECN1313 EI53C9.25 TS5213N2531 |
| 制动器 Brake | | | |
| EMFR DC110V/2.1A[2X400Nm] | | | |

|  | | 绳槽 Ropes | | | 尺寸 Dimensions | | | | |
|---|-----|-------------|---------|---------|------------------|-------------|-----|----|----|
| | | 曳引轮直径 ØD | 宽度 F | 绳径 Ø | 绳槽数 n° | 槽距 Pitch | A | B | C |
| mm | | mm | mm | mm | mm | mm | mm | mm | mm |
| 240 | 105 | 6,5 | 10 | 9,5 | 562 | 262 | 344 | 74 | |
| 320 | 79 | 8 | 5 | 12 | | 342 | 362 | | |

1 - 数据如有更改，恕不另行通知

1 - Data are subject to change without prior notice.

2 - 我们能够提供带电源线和不带电源线两种配置的机器

2 - We are able to offer machines with and without power cable configurations.

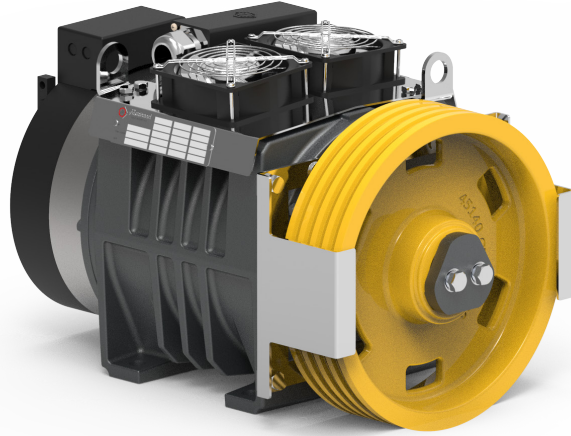

| | 额定载重 | | Ø | 绳槽 | 槽距 | 额定扭矩 | 额定功率 | 额定转速 | 额定频率 | 额定电流 | 额定电流 |
|------------|------|------|-----|---------|-------|--------|-------|------|-------|--------------|--------------|
| | Load | m/s | mm | Ropes | Pitch | Torque | Power | RPM | Freq. | Current 220V | Current 380V |
| 2:1 | kg | m/s | mm | max | mm | Nm | kW | RPM | Hz | A | A |
| | 450 | 1,00 | 320 | 5xØ8 | 12 | 229 | 2,86 | 119 | 15,9 | 16,0 | 7,6 |
| | 550 | 0,63 | 320 | 5xØ8 | 12 | 279 | 2,20 | 75 | 10,0 | 19,6 | 9,3 |
| | | 1,00 | 320 | 5xØ8 | 12 | 279 | 3,49 | 119 | 15,9 | 19,6 | 9,3 |
| | | 1,50 | 320 | 5xØ8 | 12 | 279 | 5,24 | 179 | 23,9 | 29,4 | 13,4 |
| | | 1,75 | 320 | 5xØ8 | 12 | 279 | 6,11 | 209 | 27,9 | 25,4 | 14,2 |
| | | 2,00 | 320 | 5xØ8 | 12 | 279 | 6,98 | 239 | 31,8 | 37,9 | 19,6 |
| | | 2,50 | 320 | 5xØ8 | 12 | 279 | 8,73 | 298 | 39,8 | 37,9 | 25,4 |
| | 630 | 0,63 | 320 | 5xØ8 | 12 | 320 | 2,52 | 75 | 10,0 | 22,4 | 10,7 |
| | | 1,00 | 320 | 5xØ8 | 12 | 320 | 4,00 | 119 | 15,9 | 22,4 | 10,7 |
| | | 1,50 | 320 | 5xØ8 | 12 | 320 | 6,22 | 179 | 23,9 | 33,8 | 15,3 |
| | | 1,75 | 320 | 10xØ6.5 | 12 | 320 | 7,00 | 209 | 27,9 | 33,7 | 16,2 |
| | | 2,00 | 320 | 10xØ6.5 | 12 | 320 | 8,00 | 239 | 31,8 | 43,4 | 22,4 |
| | | 2,50 | 320 | 10xØ6.5 | 12 | 320 | 10,00 | 298 | 39,8 | 43,4 | 29,1 |
| | 800 | 0,63 | 240 | 10xØ6.5 | 12 | 305 | 3,20 | 100 | 13,4 | 32,1 | 14,6 |
| | | 1,00 | 240 | 10xØ6.5 | 12 | 305 | 5,08 | 159 | 21,2 | 32,1 | 14,6 |
| | | 1,50 | 240 | 10xØ6.5 | 9,5 | 305 | 7,62 | 239 | 31,8 | 41,3 | 21,4 |
| | | 1,75 | 240 | 10xØ6.5 | 9,5 | 305 | 8,89 | 279 | 37,1 | 41,3 | 21,4 |
| | | 2,00 | 240 | 10xØ6.5 | 9,5 | 305 | 10,16 | 318 | 42,4 | 41,3 | 27,7 |

