

用途：商业服务
Use: commercial service

效率超过
Efficiency more than

80%

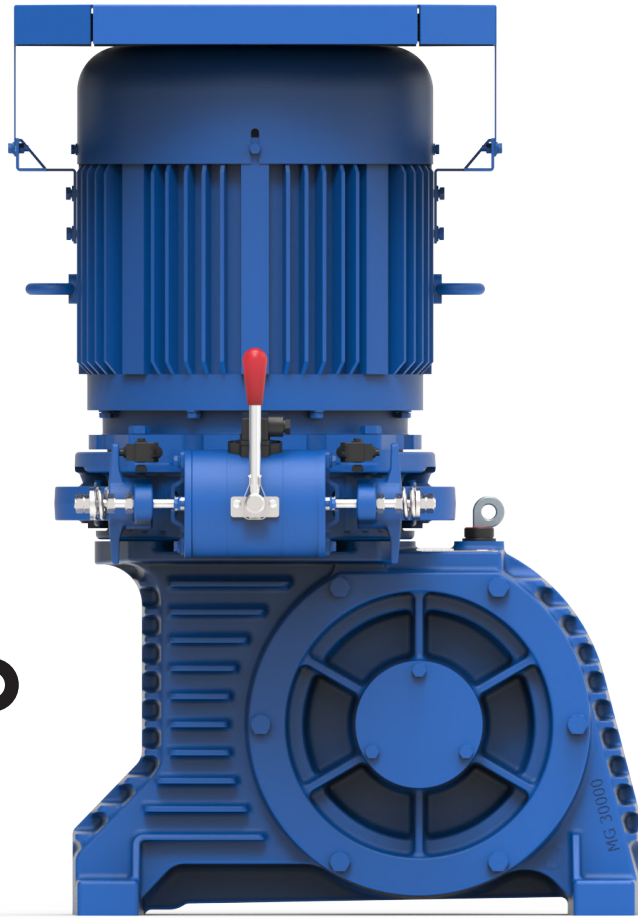

抱闸系统 - BRAKE SYSTEM

类型 - Type	启动/维持 V - Start / hold V
数据 - Data	207/104 V _{DC} S1 1,12/0,56 A - 232/116 W - 185 OHM
Booster power board 230 V _{AC}	

备注 - NOTES

保护装置 - Protection:	IP55
环境温度 - Ambient temperature:	max 40 °C
合成油 - Synthetic oil:	ISO VG460
制动器 - Brake:	2 x 140 Nm

选项 - OPTIONAL

旋转传感器 - Rotation Sensor:	PNP or NPN
磨损传感器 - Worn Sensor:	NA
制动器微动开关 - Brake Microswitch:	NO - NC AC15 2A / 250V DC13 0.25A / 250V

版本 Version	减速比 Ratio	输出速度 Output speed	最大扭矩 Max torque	功率 Power	效率 ⁽¹⁾ Efficiency	重量 Weight
		RPM	Nm	kW	满载 - Full load	kg
M93ES-7.5-6P	24.5	39.18	1499	7.5	0.85	355
M93ES-11-6P	24.5	39.18	2198	11	0.85	390
M93ES-15-6P	24.5	39.18	2998	15	0.85	410

(1) s只有齿轮箱 - only gearbox

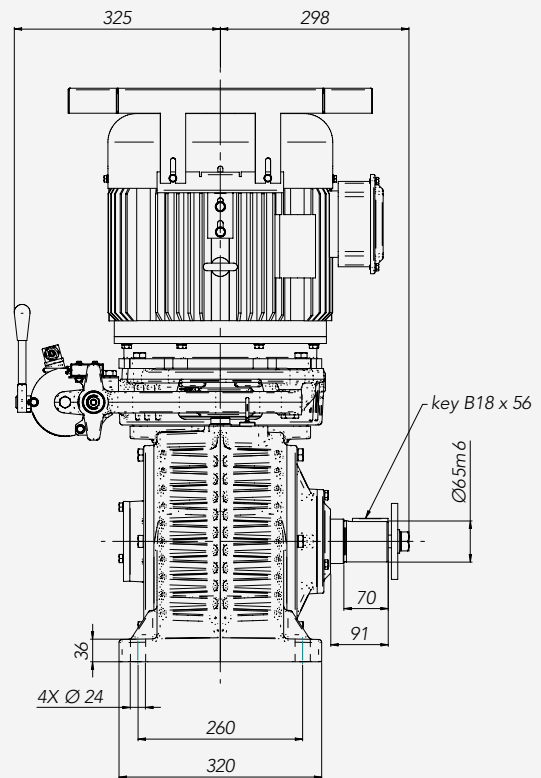
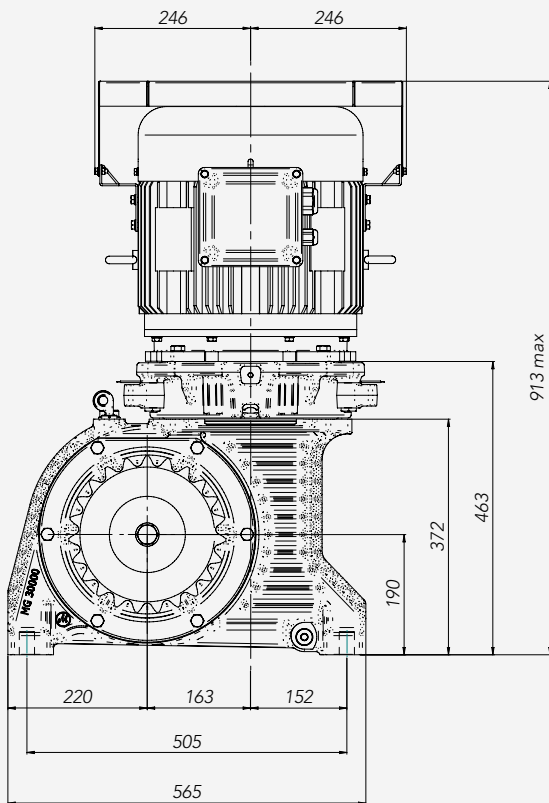
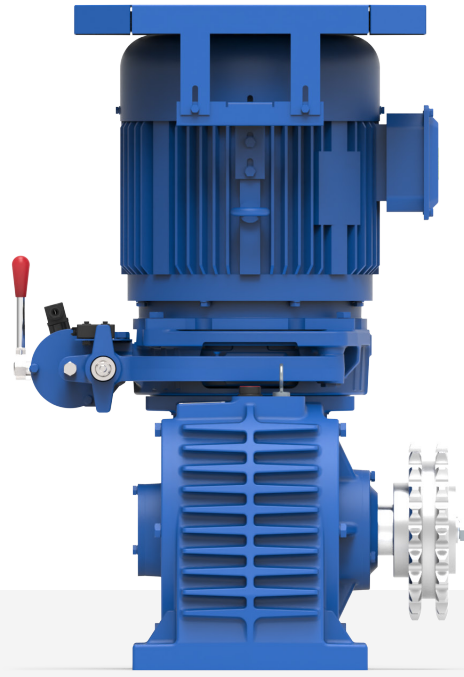

技术图纸-右置输出轴
 Technical drawing with right output shaft